

Road and Transport Research Association

Working Group for Foundation and Soils Engineering

**Technical Test Code for Soil and Rock Mechanics
in Road Construction**

TP BF-StB

Part B 8.3

Dynamic Plate-Load Testing

with the Aid of the

Light Drop-Weight Tester

Working Group for Foundation and Soils Engineering
Working Committee on Testing Equipment

Chairman:

Dipl.-Ing. T o p h i n k e, Neumünster

Members:

Dip.-Ing. B e c k e r, Köln
Dr.rer.nat. B e h r, Köln
Dipl.-Ing. B l u m e, Bergisch Gladbach
Dipl.-Geophys. B u m i l l e r, München
Dr.rer.nat D e u t l e r, Mannheim
Dipl.-Ing. F r a n z e n, Münster
Dr.-Ing. G r ä t z, Darmstadt
Dr.Dipl.-Geol. H a a g, Kornwestheim
Dr.-Ing. H a a s, Rösrath
Dipl.-Ing. H e n h a p p l, Schwerin
Dr.-Ing. K u d l a, Regensburg
Dipl.-Ing. L a m m e n, Münster
Dr.-Ing. R a h n, Berlin
Dipl.-Ing. v o n S o o s, München
Dipl.-Ing. W a l l i s, Hamburg
Prof.Dr.-Ing. W e i n g a r t, Dessau

Note:

The present test procedures "Dynamic Plate-Load Testing with the Aid of the Light Drop-Weight Tester" were drafted by the Working Committee on Testing Equipment (chairman: Dipl.-Ing. T o p h i n k e). These test procedures are included as Section B 8.3 in the compilation "Technical Test Code for Soil and Rock Mechanics in Road Construction".

Table of Contents

	Seite
1. Field of Application and Purpose	5
2. Terminology	5
2.1 Dynamic Plate-Load Test	5
2.2 Dynamic Modulus of Deformation	5
3. Tester Components	6
3.1 General	6
3.2 Load Plate	7
3.3 Loading Device	7
3.4 Device for Settling Measurement	7
3.5 Auxiliary Equipment	8
4. Test Conditions	8
5. Performing the Test	8
5.1 Preparation of the Test Area	8
5.2 Test Procedure	8
5.3 Digging Up the Test Point	9
6. Test Protocol and Evaluation	10
7. Calibration of the Light Drop-Weight Tester and Inspection of the Settling-Measurement Device	10
7.1 General	10
7.2 Calibration by a Test Institute	10
7.2.1 Loading Device	10
7.2.2 Settling-Measurement Device	12
7.3 Inspection of the Settling-Measurement Device	14
Appendix 1 Specimen of the form “Determining the Dynamic Modulus of Deformation“	15

Preface

Dynamic test procedures have been developed in various countries to enable fast testing of constructed layers of earth under load conditions approximating those imposed by road traffic.

The dynamic load test described in the following differs from the static plate-load test according to DIN 18 134 in that the load takes the form of a damped impact. The impact activates forces of inertia in the soil and in the tester, and these have an effect on the movements which have been generated.

A 300 mm load plate is preferred also for this test to ensure its comparability with static plate-load test and dynamic procedures involving vibration measuring equipment.

As a test procedure the dynamic plate-load test forms an integral part of ZTVE-StB.

The scope of this technical test code does not include permissible limit values and instructions for performing reference tests with other test procedures.

1. Field of Application and Purpose

The dynamic plate-load test is suitable for determining the bearing capacity and the compaction quality of soils and unbound base courses in earthwork and in road construction.

The test does not require much time and, hence, makes it easier to perform tests with statistical methods. In addition, it facilitates quick establishment of the degree of uniformity of the test area. Compared to the plate-load test as per DIN 18 134 this approach is advantageous as it permits measurements in confined space (e.g. utility trenches, backfill of buildings).

The test procedure is suited, in particular, for coarse-grained and mixed-grain soils with a maximum grain size of 63 mm and can be also applied to determine the dynamic modulus of deformation E_{vd} in the range from 15 to 80 MN/m².

2. Terminology

2.1 Dynamic Plate-Load Test

The dynamic plate-load test performed with the aid of the Light Drop-Weight Tester is a test procedure in which the soil receives an impact of maximum force F_s transmitted through the fall of a drop weight onto a circular load plate of radius r which is assumed to be rigid. When the device is calibrated, this force is selected such that the maximum normal stress σ under the load plate is 0.1 MN/m² in the test.

2.2 Dynamic Modulus of Deformation

Dynamic modulus of deformation E_{vd} is a parameter for the deformability of soil under a vertical impact load defined as per 2.1 and having the duration t_s (see figure 1). Its value in a particular instance is calculated in terms of the measured settling amplitude s of the load plate, in the following called settling, according to the formula

$$E_{vd} = 1.5 \cdot r \cdot \sigma / s \quad (1)$$

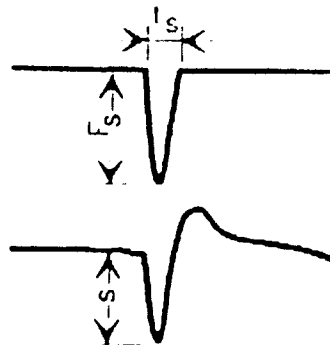

Figure 1. Time history of the impact force exerted by the Light Drop-Weight Tester and the settling it causes

3. Tester Components

3.1 General

For performing dynamic plate-load tests a Light Drop-Weight Tester as shown in Figure 2 is required.

The tester comprises:

- load plate,
- settling-measurement device arranged in the centre of the load plate at right angle to the surface receiving the load,
- loading device consisting of a drop weight, spring assembly and guide rod or guide tube with a release device.

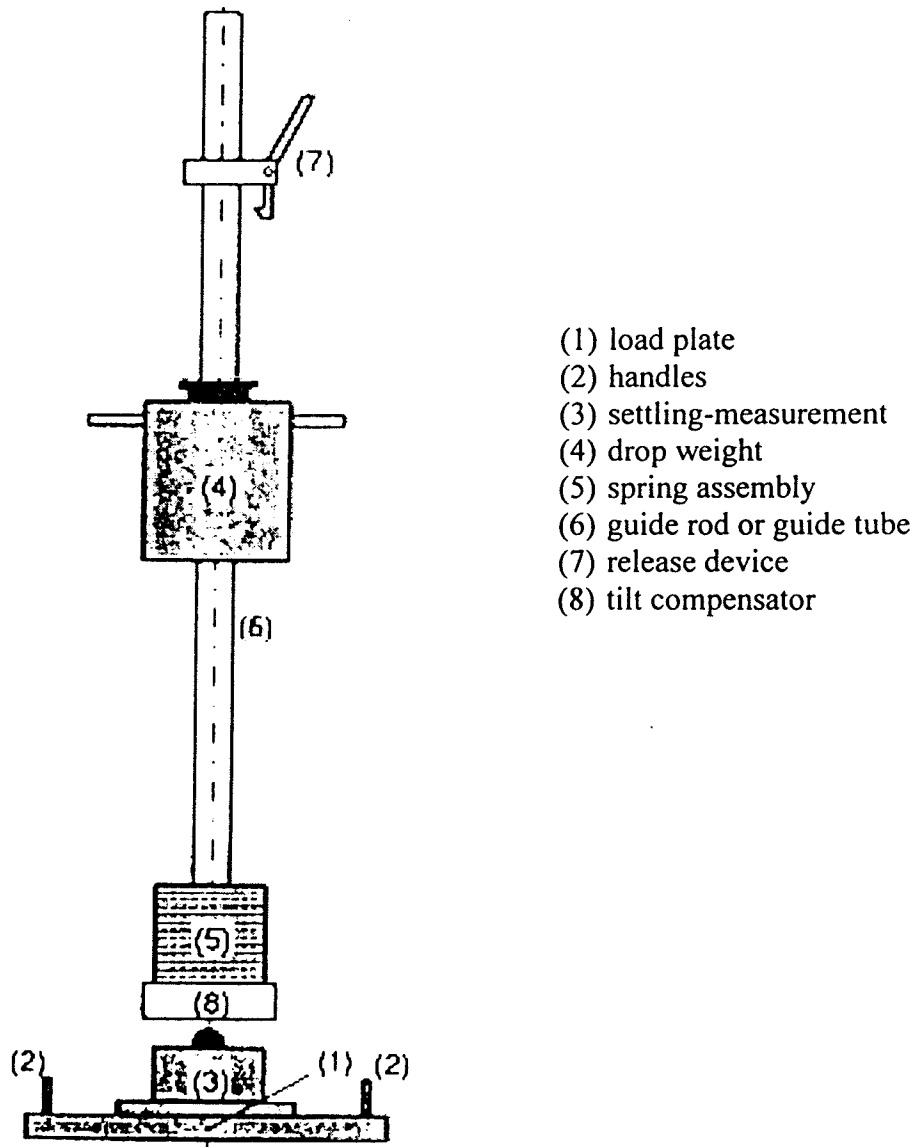

Figure 2. Simplified drawing of the Light Drop-Weight Tester

3.2 Load Plate

The dimensions of the load plate are as follows:

diameter = 300 mm

plate thickness = 20 mm or

= 17 mm with a 15 mm thick reinforcement plate (\varnothing 150 mm).

Unless otherwise stated, the tolerance for all Tester dimensions is 1%.

The material for the load plate must be steel of at least grade St. 52-3. The underside must be smooth, i.e., it must have a mean roughness of max. 6,3 μ m. The load plate must have two handles. The sensor required for settling measurements must be attached to the centre of the load plate. The mass of the load plate is:

$$15\text{kg} \pm 0.25 \text{ kg.}$$

This includes all the components mentioned above and all the parts of the settling measurement device which are attached to the load plate.

3.3 Loading Device

The loading device consists of a drop weight, a spring assembly, a guide tube or guide rod, and a release device on the limit stop at the top end of the guide rod. The Light Drop-Weight Tester has two additional extremely useful components: a tilt compensator at the bottom end of the guide rod, and a transportation lock which immobilizes the drop weight. The technical data specified for the loading-device are as follows:

mass of the drop weight = 10 kg \pm 0.1 kg

total mass of the guide rod = 5 kg \pm 0.25 kg (including components (5) to (8))

maximum impact force F_s = 7.07 kN

duration of impact t_s = 18 ms \pm 2 ms.

The spring assembly and the drop weight have to be calibrated in accordance with section 7, so that on average the deviation of the impact force from the specified value is no greater than 1% in the temperature range between 0°C and 40°C. A check should also be performed to ensure that the impact duration is also as specified.

The drop weight must be made of steel of at least grade St 52-3, and the guide rod or guide tube must be of polished high-grade steel. The drop weight must be shaped in such a way that it can be caught after the first impact on the load plate. In addition, appropriate design and maintenance measures should be taken to ensure that friction between the drop weight and the guide rod is minimal at all times.

3.4 Device for Settling Measurement

For the measurement of settling, equipment should be used which will guarantee a measuring error of no more than 2% in the frequency range from 8 Hz to 100 Hz and in the temperature range from 0°C to 40°C.

For the settling amplitude the required measuring accuracy is

\pm 0.02 mm in the range from 0.2 mm to 1.0 mm and

\pm 2% in the range from 1.0 mm to 2.0 mm.

3.5 Auxiliary Equipment

- Spade,
- steel ruler,
- hair broom,
- mason's trowel, spattle, medium-grained dry sand.

4. Test Conditions

The dynamic plate-load test can be conducted on coarse-grained and mixed-grain soils as well as on stiff or solid fine-grained soils. The percentage of grains in the soil larger than 63 mm must be negligible.

If the test is to be conducted on fast-drying, even-grained sands, on crusted soils, or on soils with sodden surfaces or whose upper layer has been disturbed in some other way, the disturbed zone must in all cases be removed before testing begins. The density of the soil being tested must be altered as little as possible.

Test results for fine-grained soils (silts, clays) can only be satisfactorily obtained and evaluated when these soils are stiff to solid in their consistency.

The incline of the test area must not exceed 6%.

5. Performing the Test

5.1 Preparation of the Test Area

The test area should be prepared so that the load plate can be placed on as even a surface as possible. This surface should have been levelled with suitable tools (steel ruler or trowel) or by pushing and rotating the load plate. Loose particles of earth should be removed. The entire undersurface of the load plate must be in contact with the subgrade. If necessary, fill out any unevenness with dry medium-grained sand. Filler, however, must not spill over from the hollows under the load plate.

5.2 Test Procedure

After the test surface has been prepared and the load plate has been positioned on the soil, the loading device is centred on the load plate, and the device for measuring the settling amplitude at the centre of the load plate is made ready for testing. The guide rod should be held vertically, even when the test surface is not horizontal.

Testing should be preceded by three preliminary impacts on the test surface so that the load plate is in perfect contact with the soil beneath. The drop weight is allowed to fall freely from the calibrated height and is captured and held after each impact.

After the settling-measurement device has been switched on, the drop weight is released three times and the settling amplitudes resulting from the three impacts are measured to within an accuracy of ± 0.02 mm. Care must be taken to ensure that the drop weight falls from exactly the specified height and is caught after each impact.

The test result should not be evaluated if there is any lateral movement of the load plate as a result of the impact of the drop weight. (This may be the case if the incline of the subgrade is too great.)

5.3 Digging Up the Test Surface

If the measurement results obtained are unusual (e.g. if there is considerable tilting, or the load plate sinks much further into the soil than expected, or the values of settlements belonging together differ by more than one quarter), then a depth of earth under the test surface equal to the diameter of the plate should be dug up, or the measurement repeated at another test location.

For fine-grained soils compliance with the consistency indicated in Section 4 must be proven for each testing lot by digging up at least one test area to a depth of 30 cm.

If digging uncovers soils with consistencies which are less than stiff, or soils with a very high or very low water content, or with stones or other interfering objects in them, these findings should be entered in the test protocol.

6. Test Protocol and Evaluation

The test protocol must contain the following data:

- building project
- manufacturer/serial number
- location of the test area
- type of soil
- weather (including temperature and time, if appropriate)
- remarks concerning deviations from the specified procedure and unusual occurrences
- results of diggings, if appropriate
- settling amplitudes measured at each test location
- the dynamic modulus of deformation E_{vd} calculated in terms of the mean value \bar{s} of the settling amplitudes.
- date of test
- inspection personnel

A specimen of the form for determining the dynamic modulus of deformation E_{vd} is contained in Appendix 1.

The dynamic modulus of deformation E_{vd} is calculated according to formula (1), assuming that:

- the formula for the specified normal-stress amplitude under the load plate is $\sigma = 0.1 \text{ MN/m}^2$
- the formula for the load-plate diameter is $2 \cdot r = 300 \text{ mm}$
- the formula, (2), for calculating the mean value \bar{s} of the settling amplitudes measured in mm is as follows:

$$E_{vd} = 22.5/s \tag{2}$$

7. Calibration of the Light Drop-Weight Tester and Inspection of the Settling-Measurement Device

7.1 General

Prior to the delivery by manufacturers and after repairs the loading device and the settling-measurement device are required to be calibrated. Calibration of must be repeated at least once per year. Presently, the following institutions are available for this purpose:

- Technischer Überwachungsverein, Hamburg
- Materialprüfanstalt, Dortmund
- Landesmaterialprüfamt Sachsen-Anhalt, Magdeburg
- Forschungs- und Materialprüfungsanstalt Baden-Württemberg, Stuttgart
- Hochschule für Technik und Wirtschaft, Dresden
- Prüfamt für Grundbau, Bodenmechanik und Felsmechanik der Technischen Universität München
-
- Materialprüfamt des Landes Brandenburg, Berlin.

Calibration is required to ensure the operability of the device as well as the compliance with the requirements for the loading device and the settling-measurement device.

Upon calibration the loading device or the settling-measurement device should be marked by a durable label. This label must contain the name of the calibration authority and the validity of calibration.

During the calibration interval the users should inspect the accuracy of the settling-measurement device. For devices which are regularly used it is recommended to perform an inspection every three months.

7.2 Calibration by a Test Institute

7.2.1 Loading Device

The loading device is calibrated through the height-of-fall setting. In addition, calibration is possible by adjusting the prestressing of the spring assembly in devices with spring washers. The mass of the drop weight itself should not be altered.

New spring assemblies should be prestressed with at least 100 impacts before the loading device is calibrated. The calibration procedure should not begin until at least 1 hour after the last prestressing impact.

The following equipment is required for the calibration of the loading device:

- drop weight with guide rod or guide tube and spring assembly
- load cell with a rated load of 20 to 50 kN
- test amplifier with a low-pass filter of at least the fourth order (critical frequency 200 Hz at 3 dB damping) with filter characteristics as presented by Butterworth
- device which will register the entire course of the force curve (e.g. a storage oscilloscope with a resolution of not less than 12 bit or a personal computer).

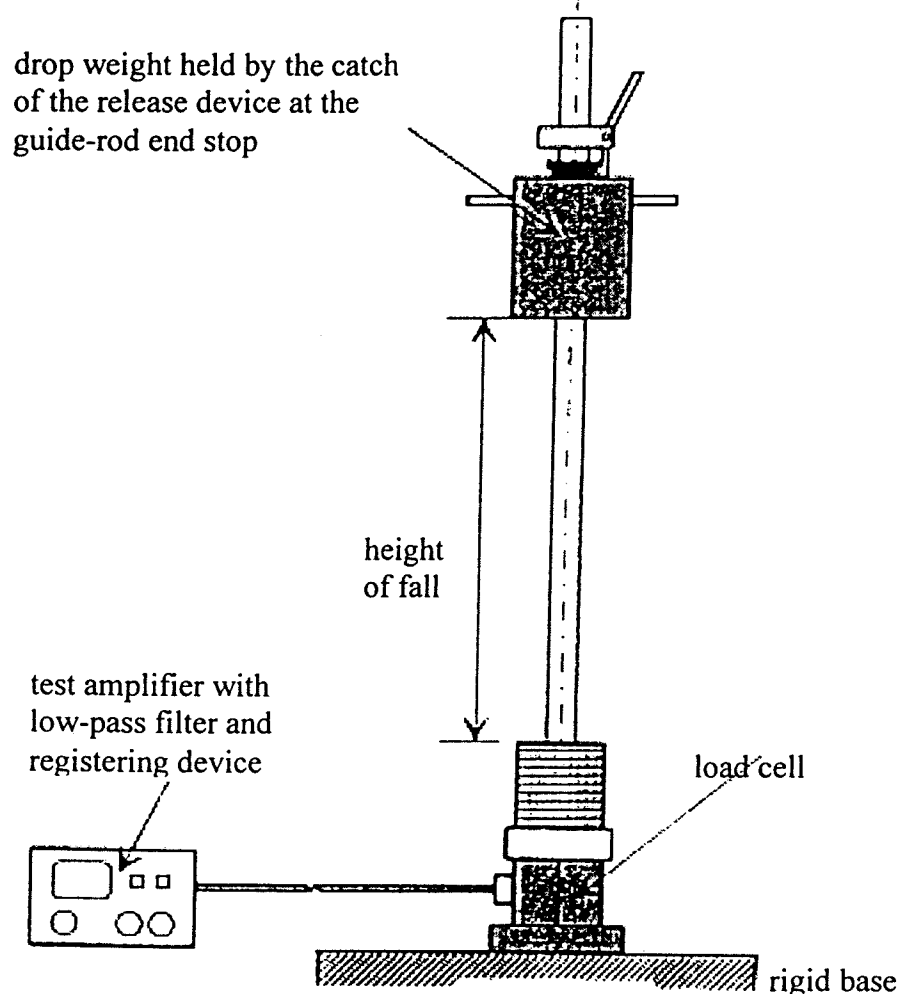

Figure 3. Simplified drawing showing the set-up for the calibration of the loading device

It must be ensured that the load cell stands on a rigid base and does not generate any interfering vibrations as a result of the impact load. The rigid base should be a concrete foundation sized not less than 0.8 m in length, 0.8 m in width and 0.5 m in height.

The test amplifier should be made ready for the start of testing in accordance with the operating instructions. During the load tests the guide rod must be kept in a vertical position. It should be perfectly clean to ensure minimum friction.

The drop weight should be released not less than ten times from the same height of fall. The measuring results are documented in the form or any computer print and the mean values \bar{t}_s and \bar{F}_s are determined. If the mean value \bar{F}_s deviates from the desired value of the impact force $F_s = 7.07$ kN by more than $\pm 1\%$, the height of fall should be adjusted until the permissible tolerance for the impact force is obtained. Individual values should not deviate from the mean of the measured values by more than $\pm 2\%$.

The height of fall h_s determined for an impact force $F_s = 7.07$ kN should be permanently displayed on the loading device. The height of fall may be defined as the distance between the underside of the drop weight when it is engaged in the release device and the impact surface on the upper side of the spring assembly. (see figure 3)

If the measured duration of impact t_s at the height of fall h_s does not fall within the permissible tolerance of ± 2 ms of the required duration of impact $t_s = 18$ ms, a different spring assembly should be used which will meet the requirements.

7.2.2 Settling-Measurement Device

The settling-measurement device must be calibrated by the calibrated drop weight and across the entire measurement range from 0.2 mm to 2 mm. Calibration is based on a comparison of the reading S_{LDWT} at the settling-measurement device with the settling values S_A , S_B and S_C measured by means of the inductive travel sensors together with the carrier frequency amplifiers for points A, B and C of the load plate. These points must be arranged as close to the centre of the load plate as possible at 120° displacement.

The following equipment (see figure 4) is required for the calibration of the settling-measurement device:

- rigid base (for a description refer to Section 7.2.1)
- steel base plate (diameter: 340 mm; mass: 30 kg \pm 0.25 kg) as an equivalence mass for the averagely covibrating half-space mass of the subgrade. To perform the calibration the load plate should be attached to the base plate with a quick-clamping device.
- three different rubber layers, each made of, for example, foam rubber of a specific hardness and thickness. After an impact of 0.1 MN/m² these bases should allow the load plate to settle by, respectively, 0.1 mm to 0.7 mm, 0.7 mm to 1.3 mm, and 1.3 mm to 2 mm.
- inductive travel sensor suitable for recording impacts (e.g. Model W2 ATK of Hottinger-Baldwin-Messtechnik) or other suitable measuring systems. The equipment described here, which comprises inductive travel sensors, ensures sufficient accuracy and reliability. Other methods, such as laser technology, are also acceptable if they fulfil these accuracy requirements.
- measuring bridge or stand
- test amplifier for the inductive travel sensor with a low-pass filter of at least the fourth order (critical frequency 200 Hz at 3 dB damping, Butterworth filter characteristics, e.g. Model MGC or DMC+, 4.8 Hz carrier frequency amplifier of Hottinger-Baldwin-Messtechnik). The instrument must ensure that the zero point of the settling is determined not until after the drop weight has been released.

- device for registering the entire settling sequence (e.g., a storage oscilloscope with a resolution of not less than 12 bit or a personal computer).

The concrete base must have a horizontal and flat surface. The supporting plate is placed on one of the rubber layers, i.e. first on the layer intended for the measuring range of $1 \text{ mm} \pm 0.3 \text{ mm}$, and the load plate is attached to the supporting plate.

The measuring bridge or the stand are arranged on a rigid base at a sufficient distance from the load plate centre to prevent transmission of any interfering vibrations. The inductive travel sensors are attached to the points A, B and C of the load plate. It is essential that the sensor tips make firm contact with the load plate.

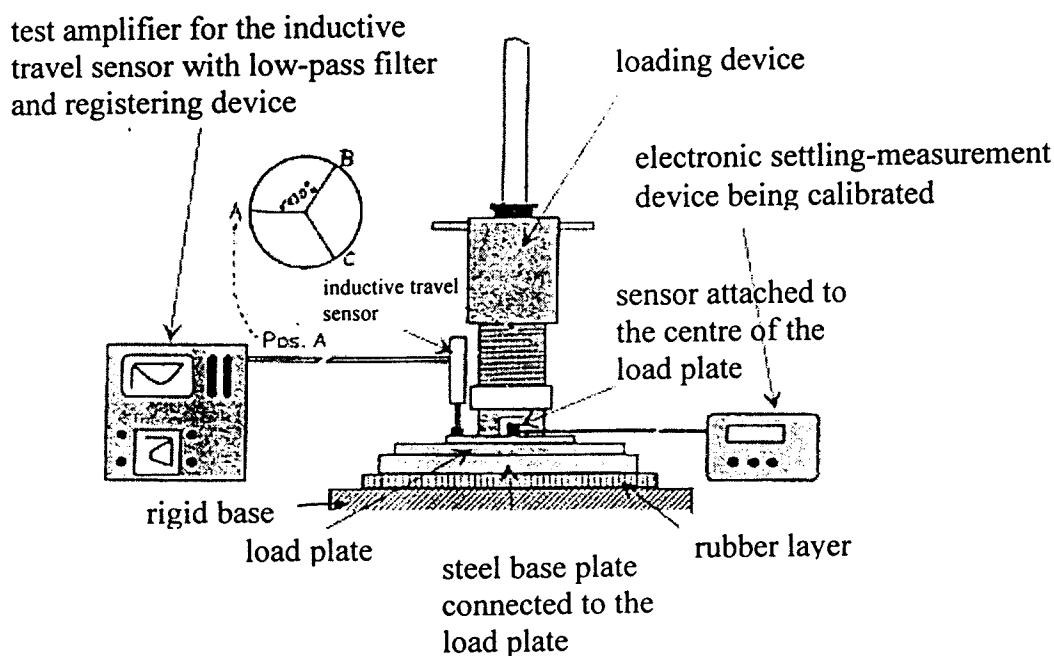

Figure 4. Simplified drawing showing the set-up for the calibration of the settling-measurement device

For calibration the loading device is placed onto the centre of the load plate, the measuring units are made ready in compliance with the relevant operating instructions, and the drop weight is allowed to fall ten times, i.e. $n = 10$ impacts, from the height specified in Section 7.2.1. For recording and evaluating the results a form as per Appendix 2.2 should be used.

The settling amplitudes measured with the settling-measurement device should be compared with the results obtained by means of the inductive travel sensor. If the difference between the means of the two sets of measured values is more than 0.02 mm, the settling-measurement device should be adjusted in accordance with the operating instructions of the manufacturer and the calibration procedure repeated.

The discrepancy between the respective individual measured values should not be greater than 0.04 mm. 10 further comparison measurements should be performed with each of the two other layers of rubber to demonstrate that the readings lie within the required tolerance limits across the entire range of hardnesses. The mean settling distance required with the softer layer is $0.4 \text{ mm} \pm 0.3 \text{ mm}$, and with the harder layer $2 \text{ mm} \pm 0.3 \text{ mm}$.

7.3 Inspection of the settling-measurement device by users

This inspection is aimed at establishing whether sufficient repeatability of settling measurements under the defined conditions is ensured.

The following equipment is required for inspection:

- rigid and even base with a total weight of not less than 200 kg (e.g. concrete foundation),
- rubber layer for about 1 mm settling (refer to Section 7.2.2).

The rubber layer belongs to the basic equipment of the Light Drop-Weight Tester. Availability of spare layers should be ensured by the manufacturers of the tester.

The base, remaining unaltered, must be available for not less than 1 year. The inspection should be performed at room temperature. Prior to the start of inspection measurements the Light Drop-Weight Tester must be allowed to adapt to the room temperature.

The rubber layer is placed on the even base. Ten individual impacts on the rubber layer are performed in measurement mode. The settling results S_{iN} should be documented and evaluated in a form. The first inspection should be carried out as a zero measurement immediately upon delivery or calibration prior to commissioning of the device.

For the 10 settling values S_{iN} ($i = 1, \dots, 10$) of the zero measurement the difference between the highest and the smallest values must not exceed 0.04 mm.

The following two conditions must be fulfilled for the inspection measurements j :

- (1) The difference between the highest and the smallest values of the 10 settlings ($i = 1, \dots, 10$) must not exceed 0.04 mm.
- (2) The absolute difference between the mean value \bar{S}_i and the inspection measurement No. j and the mean value \bar{S}_N of the zero measurement must not exceed 0.02 mm.

If these requirements are not fulfilled, calibration by a test institute as per Sections 7.1 and 7.2 is required. Users' inspections of the settling-measurement device do not replace annual calibrations as per Sections 7.1 and 7.2.